

SHARP®

MODEL
AR-155
AR-155N

DIGITAL LASER COPIER
OPERATION MANUAL

	Page
• GETTING STARTED	3
• MAKING COPIES	12
• SPECIAL FUNCTIONS	20
• SUPPLIES AND USER MAINTENANCE	23
• COPIER TROUBLE?	29
• APPENDIX	38
• OPTIONAL EQUIPMENT	42

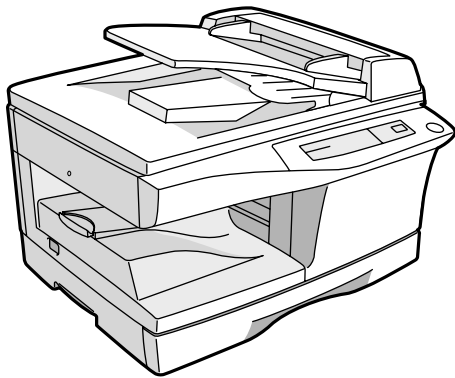

CLASS 1 LASER PRODUCT

LASER KLASSE 1

LUOKAN 1 LASERLAITE

KLASS 1 LASERAPPARAT

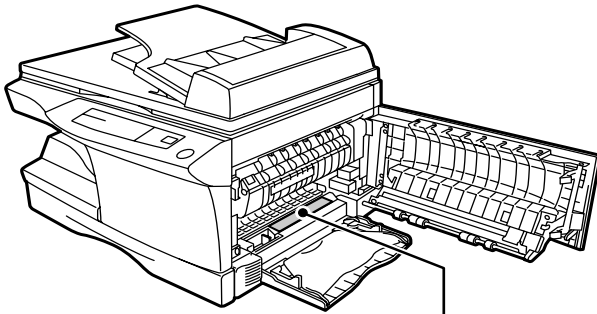

VAROITUS!

LAITTEEN KÄYTTÄMINEN MUULLA KUIN TÄSSÄ KÄYTTÖOHJEESSA MAINITULLA TAVALLA SAATTAA ALTISTAA KÄYTTÄJÄN TURVALLISUUSLUOKAN 1 YLITTÄVÄLLE NÄKYMÄTTÖMÄLLE LASERSÄTEILYLLE.

VARNING

OM APPARATEN ANVÄNDS PÅ ANNAT SÄTT ÄN I DENNA BRUKSANVISNING SPECIFICERATS, KAN ANVÄNDAREN UTSÄTTAS FÖR OSYNLIG LASERSTRÅLNING, SOM ÖVERSKRIDER GRÄNSEN FÖR LASERKLASS 1.

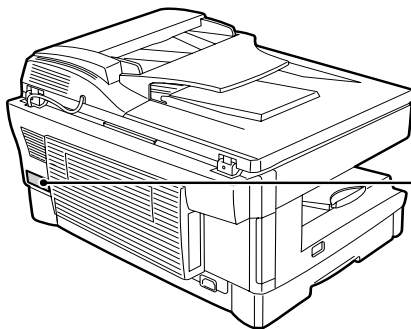
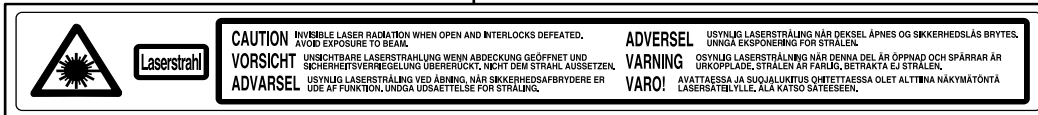

**CLASS 1
LASER PRODUCT
LASER KLASSE 1**

Caution

This product contains a low power laser device. To ensure continued safety do not remove any cover or attempt to gain access to the inside of the product. Refer all servicing to qualified personnel.

CONTENTS

1 GETTING STARTED

INTRODUCTION	3
CAUTIONS	4
MAIN FEATURES	5
PART NAMES	6
OPERATION PANEL	7
COPIER INSTALLATION	8
CAUTIONS ON HANDLING	9
LOADING COPY PAPER	10

2 MAKING COPIES

NORMAL COPYING	12
– Stream feeding mode	16
EXPOSURE ADJUSTMENT/PHOTO COPYING	16
REDUCTION/ENLARGEMENT/ZOOM	17
BYPASS FEED (including special paper)	18

3 SPECIAL FUNCTIONS

DESCRIPTION OF SPECIAL FUNCTIONS	20
TONER SAVE MODE	20
USER PROGRAMS (power save modes, auto clear time, stream feeding mode)	21
– Setting the power save modes, auto clear time, and stream feeding mode	21
DISPLAYING TOTAL NUMBER OF COPIES	22

4 SUPPLIES AND USER MAINTENANCE

- TD CARTRIDGE REPLACEMENT 23
- DRUM CARTRIDGE REPLACEMENT 25
- USER MAINTENANCE 27
 - Cabinet 27
 - Original table and original cover 27
 - Transfer charger 27
 - When copier is not in use 28

5 COPIER TROUBLE?

- MISFEED REMOVAL 29
 - A Misfeed in the paper feed area 30
 - B Misfeed in the fusing area 30
 - C Misfeed in the transport area 31
 - D Misfeed in the RSPF 32
- MAINTENANCE REQUIRED 34
- TROUBLESHOOTING 35
- STATUS INDICATORS 36
- AUTOMATIC EXPOSURE ADJUSTMENT 37

6 APPENDIX

- SPECIFICATIONS 38
- SUPPLIES 40
 - Types and sizes of copy paper 40

7 OPTIONAL EQUIPMENT

- SYSTEM CONFIGURATION 42
- 250-SHEET PAPER FEED UNIT (AR-DE9) 43
 - Part names 43
 - Loading copy paper 43
 - Misfeed removal 43
 - Specifications 44

INDEX

1

GETTING STARTED

This chapter provides basic information for using the copier.

INTRODUCTION

This copier has been designed to provide intuitive operating ease while requiring a minimum amount of space. To get full use of all copier features, be sure to familiarise yourself with this manual and the copier.

For quick reference during copier use, keep this manual in a handy location.



Note

This copier can also be used as a laser printer if an optional printer expansion kit is installed. This manual describes only the copier features. For description of the printer features, see the separate manual.

Conventions used in this manual

In this manual, the following icons are used to provide the user with information pertinent to the use of the copier.



Warning

Warns the user that injury to the user or damage to the copier may result if the contents of the warning are not properly followed.



Caution

Cautions the user that damage to the copier or one of its components may result if the contents of the caution are not properly followed.



Note

Notes provide information relevant to the copier regarding specifications, functions, performance, operation and such, that may be useful to the user.



Indicates a letter displayed in the display.

AB series (metric) and inch series references

When references are made to paper sizes and weights, the inch series values are quoted in brackets.

For example:

Page 40 ----- 56 to 80 g/m² (15 lbs. to 21 lbs.)
A4 (8-1/2" x 11")

CAUTIONS

Follow the cautions below when using this copier.

1

Getting started



Warning

- The fusing area is hot. Exercise care in this area when removing misfed paper.
- Do not look directly at the light source. Doing so may damage your eyes.
- Do not switch the copier rapidly on and off. After turning the copier off, wait 10 to 15 seconds before turning it back on.
- Copier power must be turned off before installing any supplies.



Caution

- Place the copier on a firm, level surface.
- Do not install the copier in a humid or dusty location.
- When the copier is not used for long time, for example for consecutive holidays, turn the power switch off and remove the power cord from the outlet.
- When moving the copier, be sure to turn the power switch off and remove the power cord from the outlet.
- Do not cover the copier with a dust cover, cloth or plastic film while the power is on. Doing so may prevent heat radiation, damaging the copier.



Caution

Use of controls or adjustments or performance of procedures other than those specified herein may result in hazardous radiation exposure.

Cautions on laser

Wave length	785 nm \pm 15 nm
Pulse times	(4.0 μ s \pm 4 ns)/7 mm
Output power	0.25 mW - 0.50 mW

MAIN FEATURES

① High-speed laser copying

- Since warm-up time is zero, copying can be started immediately after the power switch is turned on.
- First-copy time is only 9.6 seconds (normal mode).
- Copying speed is 15 copies/min., which adapts to business use, allowing improvement of working efficiency.

② High-quality digital image

- High-quality image copying at 600 dpi can be performed.
- In addition to the automatic exposure mode, the manual exposure can be adjusted in five steps.
- The photo mode copying function allows clear copying of delicate halftone original images such as monochrome photos and colour photos.

③ Substantial copying functions

- Zoom copying from 50% to 200% in 1% increments can be performed.
- Continuous copying of maximum 99 sheets can also be performed.
- Automatic document feeding through the reversing single pass feeder (RSPF) can be performed.
- Toner save mode reduces toner consumption by approximately 10%.
- User programs allow setting/modification of functions for customer's needs.
- Automatic two-sided copying can be performed.

④ Scan once/ Print many

- This copier is equipped with a 1-page memory buffer. This Memory allows the copier to scan an original once only and make up to 99 copies. This feature allows for improved workflow, reduced operating noise from the copier and reduced wear and tear on the scanning mechanism. This feature provides for a higher reliability.

⑤ Printer feature

- This copier can be used as a laser printer by installing an optional printer expansion kit.

⑥ Environmentally friendly design

- Paper output tray is housed in the copier for space saving.
- Preheat mode and auto power shut-off mode are provided to reduce power consumption in standby mode.



Note

This copier does not have an internal calendar or clock.
This copier will not be affected by the year 2000.

PART NAMES

1

Getting started

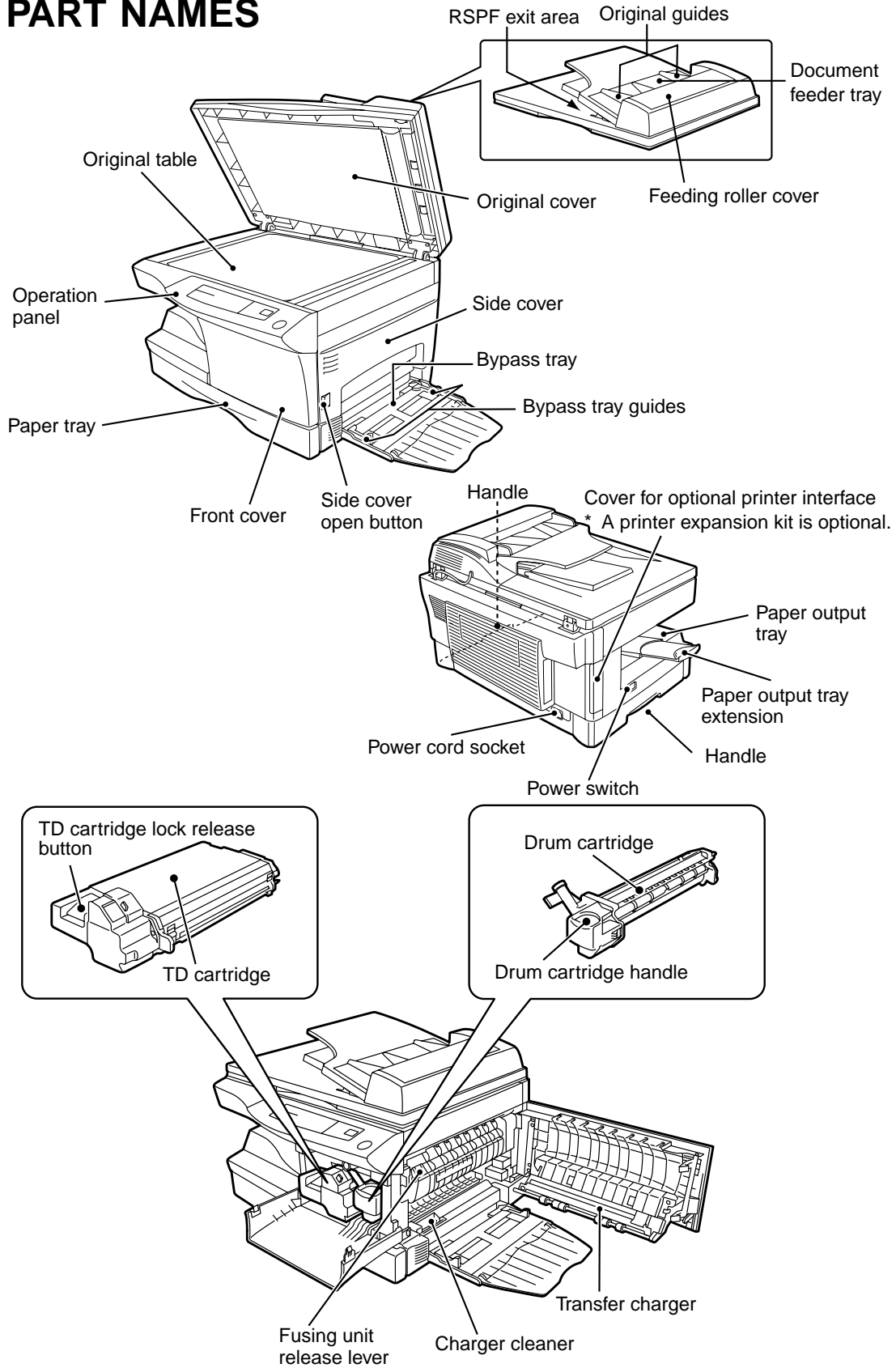

OPERATION PANEL

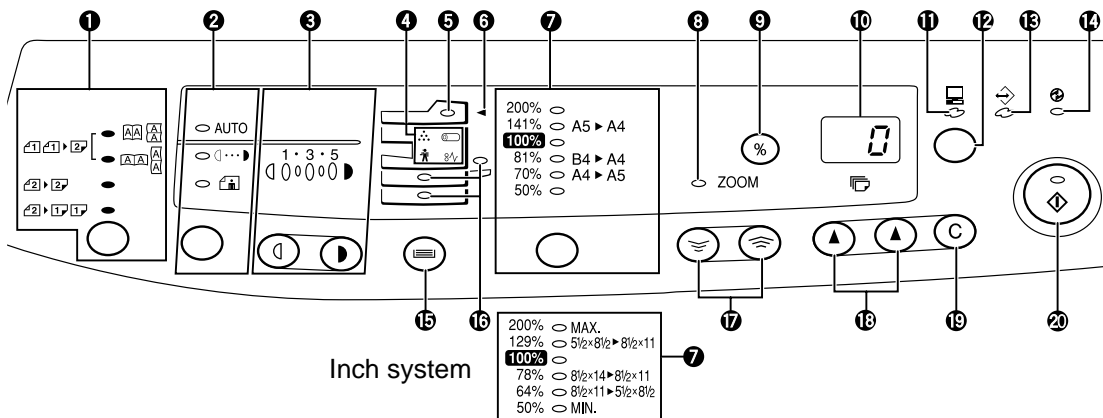

1 Original to copy key and indicators

- : Two-sided copies from one-sided originals.
 Turn on Long Edge or Turn on Short Edge can be selected.
- : Two-sided copies from two-sided originals. (Can be selected only when the RSPF is used.)
- : Single-sided copies from two-sided originals. (Can be selected only when the RSPF is used.)

2 Exposure mode selector key and indicators

Use to sequentially select the exposure modes: AUTO, MANUAL or PHOTO. Selected mode is shown by a lit indicator. (p. 16)

3 Light and dark keys and exposure indicators

Use to adjust the MANUAL or PHOTO exposure level. Selected exposure level is shown by a lit indicator. (p.16)

Use to start and terminate user program setting. (p. 21)

4 Alarm indicators

- : Drum replacement required indicator (p. 25)
- : Misfeed indicator (p. 29)
- : TD cartridge replacement required indicator (p. 23)
- : Maintenance indicator (p. 34)

5 RSPF indicator (p. 13)

6 RSPF misfeed indicator (p. 32)

7 Copy ratio selector key and copy ratio indicators

Use to sequentially select preset reduction/enlargement copy ratios.
 Selected copy ratio is shown by a lit indicator. (p. 17)

8 Zoom indicator (p. 17)

9 Copy ratio display (%) key (p. 17)

10 Display

Displays the specified copy quantity, zoom copy ratio, user program code, and error code.

11 ON LINE indicator

Lights up when the machine is used as a printer. To use the copier as a printer, an optional printer expansion kit is needed.

12 ON LINE key

Changes between the on-line and off-line modes when the PCL expansion kit has been installed and a PCL printer is used.

Changes modes from the off-line to on-line when the GDI expansion kit has been installed and a GDI printer is used.

13 DATA indicator

Indicates that the printer is receiving or processing print data. To use the copier as a printer, an optional PCL expansion kit is needed.

14 Power save indicator

Lights up when the copier is in a power save mode. (p. 20, 21)

15 Tray select key

Use to select a paper feed station (paper tray or bypass tray). (p. 19)

16 Paper feed location indicators

Light up to show the selected paper feed station.

17 Zoom keys

- Use to select any reduction or enlargement copy ratio from 50 to 200% in 1% increments. (p. 17)

18 Copy quantity keys

- Use to select the desired copy quantity (1 to 99). (p. 15)
- Use to make user program entries. (p. 21)

19 Clear key

- Press to clear the display, or press during a copy run to terminate copying. (p. 15)
- Press and hold down during standby to display the total number of copies made to date. (p. 22)

20 Print key and ready indicator

- Copying is possible when the indicator is on.
- Use to set a user program.

COPIER INSTALLATION

Improper installation may damage the copier. Please note the following during initial installation and whenever the copier is moved.

1

Getting started



Caution

If the copier is moved from a cool place to a warm place, condensation may form inside the copier. Operation in this condition will cause poor copy quality and malfunctions. Leave the copier at room temperature for at least 2 hours before use.

Do not install your copier in areas that are:

- damp, humid, or very dusty
- exposed to direct sunlight
- poorly ventilated
- subject to extreme temperature or humidity changes, e.g., near an air conditioner or heater.

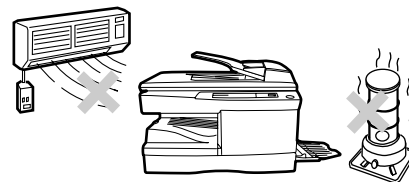
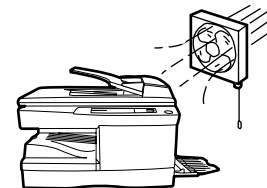
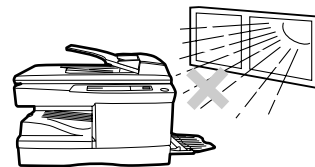
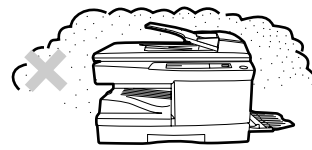

The copier should be installed near an accessible power outlet for easy connection.

Be sure to connect the power cord only to a power outlet that meets the specified voltage and current requirements. Also make certain the outlet is properly grounded.



Note

Connect the copier to a power outlet which is not used for other electric appliances. If a lighting fixture is connected to the same outlet, the light may flicker.

COPIER INSTALLATION

Be sure to allow the required space around the machine for servicing and proper ventilation.

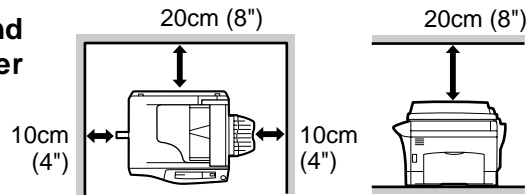

1

Getting started

CAUTIONS ON HANDLING

Be careful in handling the copier as follows to maintain the performance of this copier.

Do not drop the copier, subject it to shock or strike it against any object.

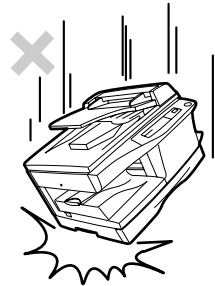

Do not expose the drum cartridge to direct sunlight.

Doing so will damage the surface (green portion) of the drum cartridge, poor print quality.

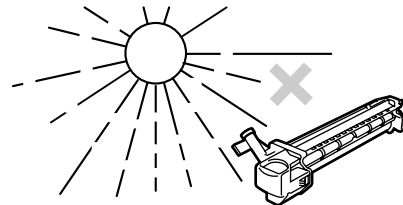

Store spare supplies such as drum cartridges and TD cartridges in a dark place without removing from the package before use.

If they are exposed to direct sunlight, poor print quality may result.

Do not touch the surface (green portion) of the drum cartridge.

Doing so will damage the surface of the cartridge, causing poor print quality.

LOADING COPY PAPER

- 1 Raise the handle of the paper tray and pull the paper tray out until it stops.

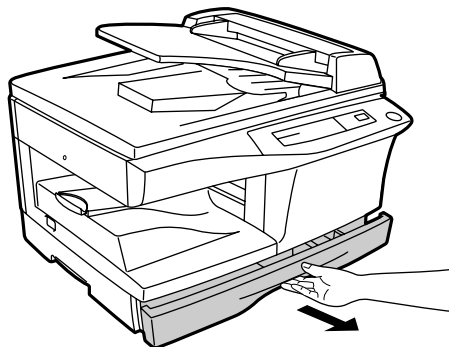

- 2 Adjust the paper guides on the paper tray to the copy paper width and length. Squeeze the lever of paper guide (A) and slide the guide to match with the width of the paper. Move paper guide (B) to the appropriate slot as marked on the tray.

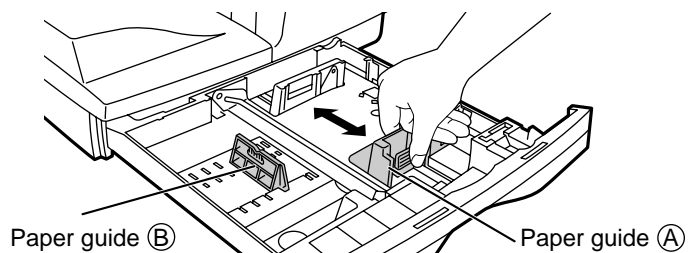

- 3 Fan the copy paper and insert it into the tray. Make sure the edges go under the corner hooks.



Note

Do not load paper above the maximum height line (▼▼). Exceeding the line will cause a paper misfeed.

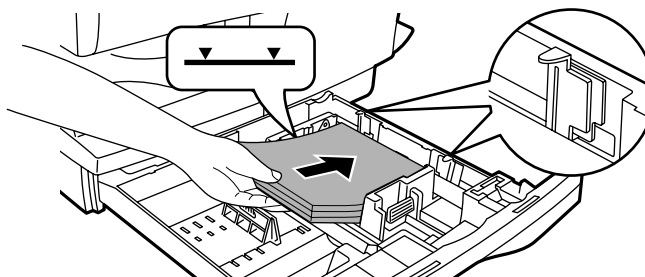

4 Gently push the paper tray back into the copier.



Note

After loading copy paper, to cancel the blinking "P" without restarting copying, press the clear (Ⓢ) key. The "P" in the display will go out and the ready (Ⓢ) indicator will light up.

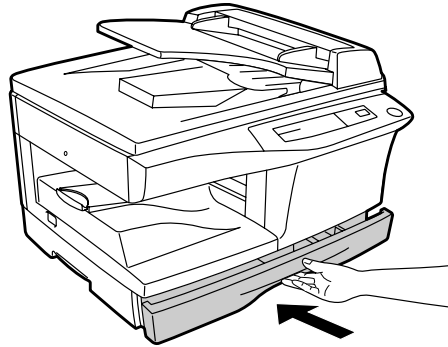

1

Getting started

2

MAKING COPIES

This chapter describes basic copying functions and some other copying functions using the bypass tray.

2

Making copies

NORMAL COPYING

This copier has two document input stations -reversing single pass feeder (RSPF) for automatic document feeding and an original table for manual handling of documents. The RSPF is designed to hold up to 30 originals measuring from A5 to B4 (5-1/2" x 8-1/2" to 10" x 14") and weighing from 52 to 90 g/m² (14 to 23 lbs.).

When copying from the RSPF, two-side originals can be copied automatically without having to manually turn them over.

Automatic two-sided copying can also be performed with this copier. When copying from one-sided originals to two-sided copies, copying orientation can be selected between Turn on Long Edge and Turn on Short Edge.

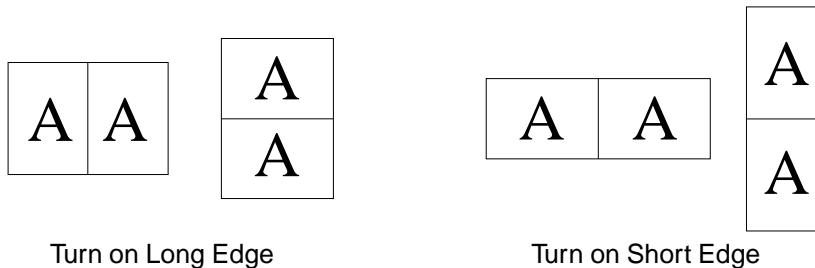

Note

- When making two-sided copies from the original table, the copy paper size must be A4 (8-1/2" x 11"). When making two-sided copies from the RSPF, letter, legal, and invoice sizes can be used. Non-standard size paper cannot be used.
- When making two-sided copies from the RSPF, a multiple number of copies cannot be set.
- When making two-sided copies, the bypass tray cannot be used.
- When using two-sided invoice size originals from the RSPF, be sure to place them in the landscape orientation. Otherwise, an original misfeed will occur.

1

Ensure that paper of the desired size is set in the paper tray. See page 10, **LOADING COPY PAPER**. When copying onto paper larger than A4 (8-1/2" x 11") size, pull out the paper output tray extension. If you use another tray, use the tray select () key to select the desired tray.

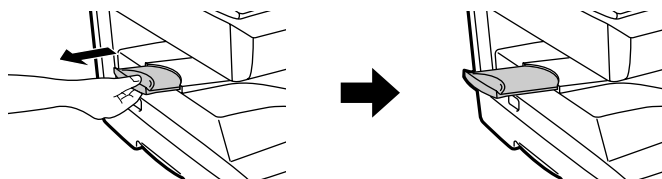

- 2** Turn the power switch on.
The ready (⊕) indicator will light up.



Note

- The copier will enter a power save mode once the set time has elapsed without any copier operation after the last copy of a run is made or power is turned on.
The settings of the power save modes can be modified. See page 21, **USER PROGRAMS.**
- The copier will return to the initial settings a preset amount of time after the last copy is made. The preset amount of time (auto clear time) can be changed. See page 21, **USER PROGRAMS.**

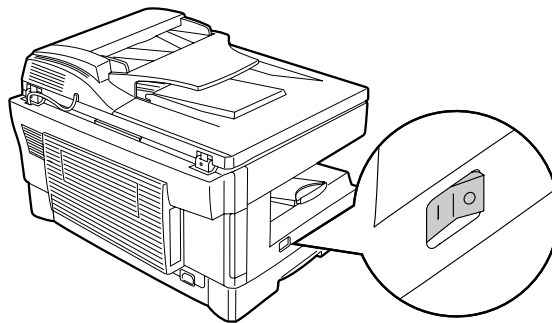

- 3** Place the original(s) face up in the document feeder tray or face down on the original table.

A. When using the RSPF:

- (1) Make sure that no original is left on the original table.
- (2) Adjust the original guides to the size of originals.
- (3) Set the originals face up in the document feeder tray.



Note

- Before feeding originals in the document feeder tray, be sure to remove any staples or paper clips from them.
- Before placing curled or wavy originals into the document feeding tray, be sure to flatten them. If not, original misfeeds may result.
- The RSPF (⊖) indicator on the operation panel will light up. If this indicator does not light up, the originals are not properly set or the RSPF is not properly closed.
- Badly damaged originals may misfeed in the RSPF. It is recommended that such originals be copied from the original table.
- Special originals such as transparency film should not be fed through the RSPF, but should be placed directly on the original table.
- Image loss (max. 4 mm (5/32")) can occur at the leading and trailing edges of the copies. Also image loss (max. 4.5 mm (11/64") in total) can occur along the other edges of the copies. It can be 6 mm (15/64") (max.) at the trailing edge of the second copy of two-sided copying.

NORMAL COPYING

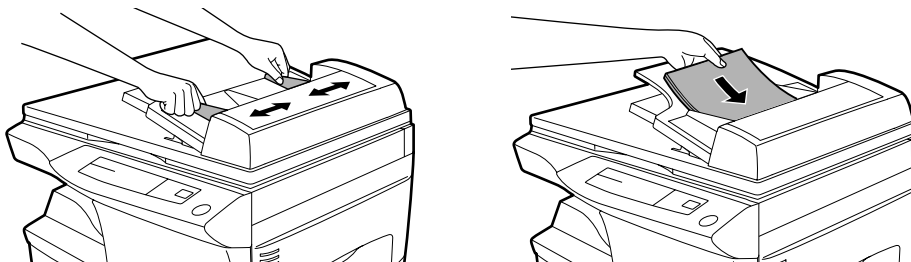

2

Making copies

B. When using the original table:

- (1) Open the original cover.
- (2) Place an original face down on the original table. Align it with the original scale and the centring (▶) mark. Close the original cover.

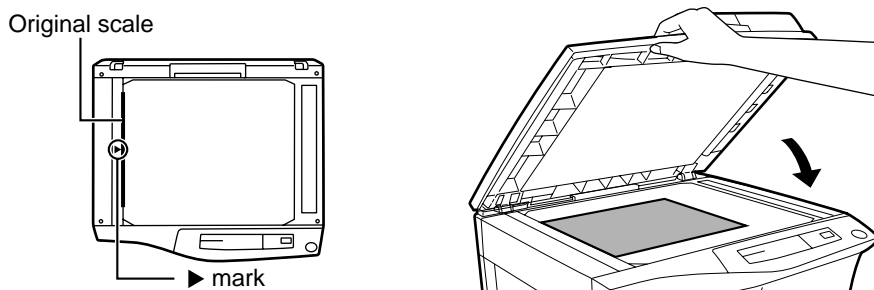

Note

When copying a book or an original which has been folded or a crumpled original, press down the original cover lightly. If the original cover is not securely closed, the copies may be striped or blurred.

A book, an original which has been folded, or a crumpled original

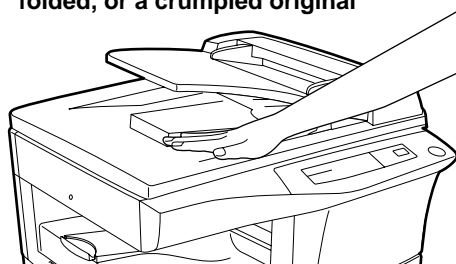

4

Select the desired original to copy mode.

A. When copying in the one-sided to one-sided mode:

Ensure that no indicator is lit among the original to copy indicators.

B. When copying in a one-sided to two-sided mode:

Use the original to copy key to select the desired one-sided to two-sided copying mode (Turn on Long Edge or Turn on Short Edge). See the illustrations on page 12.

C. When copying in the two-sided to two-sided mode:

Use the original to copy key to select the two-sided to two-sided copying mode. The originals must be set in the RSPF before this mode can be set (step 3).

D. When copying in the two-sided to one-sided mode:

Use the original to copy key to select the two-sided to one-sided copying mode. The originals must have been set in the RSPF in step 3.

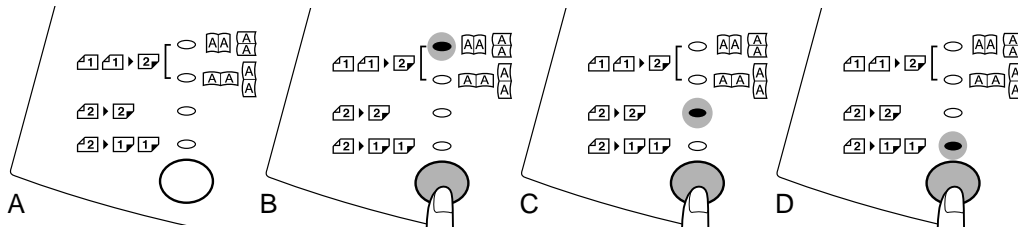

5 Ensure that the desired paper tray is selected.



Note

- Paper sizes that can be used in the duplex mode are letter, legal, and invoice. (When copying from the original table in the duplex mode, only A4 (8-1/2" x 11") size paper can be used.)
- The bypass tray cannot be used in the duplex mode.

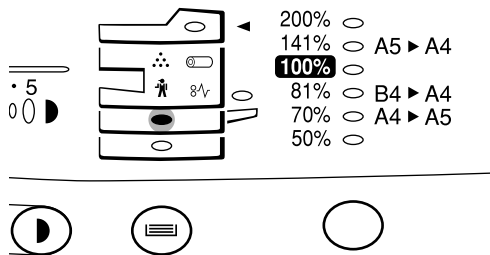

6 Set the number of copies using the two copy quantity (▲, ▲) keys when copying from the original table or copying in a 1-sided copy mode from the RSPF.



Note

- Press the clear (Ⓢ) key to clear an entry if a mistake is made.
- A single copy can be made with the initial setting, i.e., when "0" is displayed.

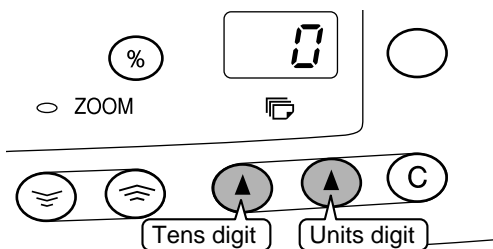

- Press the right copy quantity key to set the units digit from 0 to 9. This key will not change the tens digit.
- Press the left copy quantity key to set the tens digit from 1 to 9.

7 Press the print (Ⓢ) key.



Note

- To display the number of copies made in a continuous run, press the left copy quantity key.
- To stop copying in the middle of a run, press the clear (Ⓢ) key. Copying will stop and the number in the display will be reset to "0".

NORMAL COPYING

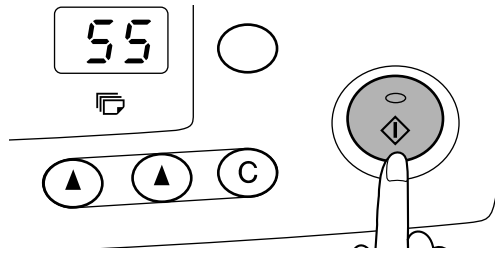



- 8 When making two-sided copies from the original table, place the second original on the original table and press the print () key.



Note



- To cancel two-sided copying after scanning the first original, press the clear () key.

Stream feeding mode



The stream feeding mode allows easy operation of continuous copying from the RSPF. If the stream feeding mode has been enabled using user program No.4, the RSPF () indicator will blink for approximately 5 seconds after the last original has been fed by the RSPF. While this indicator is blinking, any new originals placed in the document feeder tray will be fed and copied automatically. If the stream feeding mode has been disabled, the print () key must be pressed each time the originals are set even immediately after completion of a copy run from the RSPF. The default setting of the stream feeding mode is "ON". See page 21, **USER PROGRAMS**.

EXPOSURE ADJUSTMENT/PHOTO COPYING

Copy density adjustment is not required for most originals in the automatic exposure mode. To adjust the copy density manually or to copy photographs, the exposure level can be adjusted in five steps manually.

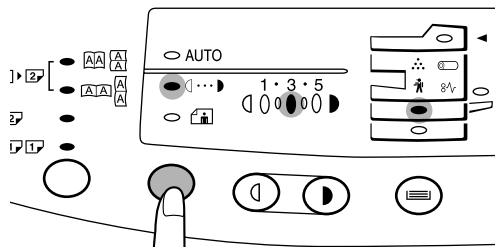
- 1 Set the original and check the copy paper size.
- 2 Press the exposure mode selector key to select the manual () mode or photo () mode.



- 3 Use the light () and dark () keys to adjust the exposure level. If exposure level 2 is selected, the two left-handmost indicators for that level will light up simultaneously. Also, if level 4 is selected, the two right-handmost indicators for that level will light up simultaneously.

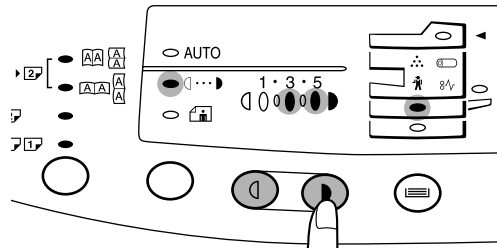

- 4 Set the number of copies using the copy quantity (▲, ▼) keys and press the print (⏏) key.

REDUCTION/ENLARGEMENT/ZOOM

Three preset reduction ratios and two enlargement ratios can be selected. The zoom function enables copy ratio selection from 50% to 200% in 1% increments.

- 1 Set the original and check the copy paper size.
- 2 Use the copy ratio selector key and/or zoom (⊖, ⊕) keys to select the desired copy ratio.



Note

- To verify a zoom setting without changing the zoom ratio, press and hold down the copy ratio display (%) key. When the key is released, the display will return to the copy quantity display.
- To reset the ratio to 100%, press the copy ratio selector key repeatedly until the 100% indicator lights up.

To select a preset copy ratio:

Preset reduction and enlargement ratios are: 50%, 70%, 81%, 141%, and 200% (50%, 64%, 78%, 129%, and 200%)

To select a zoom ratio:

When a zoom (⊖ or ⊕) key is pressed, the ZOOM indicator will light up and the zoom ratio will be displayed in the display.



Note

To decrease or increase the zoom ratio rapidly, press and hold down the ⊖ or ⊕ key. However the value will stop at the preset reduction or enlargement ratios. To move beyond these ratios, release the key and then press and hold it down again.

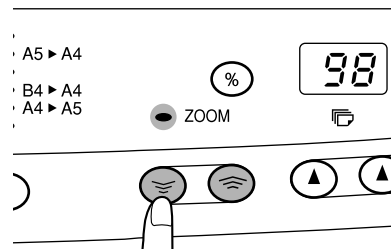
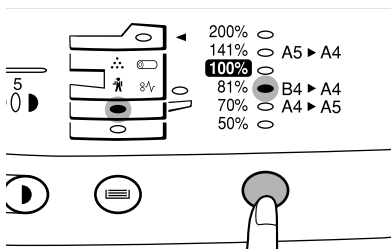

- 3 Set the number of copies using the copy quantity (▲, ▼) keys and press the print (⏏) key.

BYPASS FEED (including special paper)

The bypass tray can automatically feed up to 50 sheets of standard copy paper and can also feed special papers such as transparency film and labels one sheet at a time. Copy paper measuring from A6 to A4 (3-1/2" x 5-1/2" to 8-1/2" x 14") and in the weight range of 52 to 130 g/m² (14 to 34.5 lbs.) can be used in this tray. (For paper weighing from 104 to 130 g/m² (28 to 34.5 lbs.), A4 (8-1/2" x 11") is the maximum size.)

- 1 Place the original(s) face up in the document feeder tray or face down on the original table.



Note

The original image must be smaller than the paper or media for copying. If the original image is bigger than the paper or media, this may cause smudges on the edges of the copies.

- 2 Open the bypass tray and extend the tray.

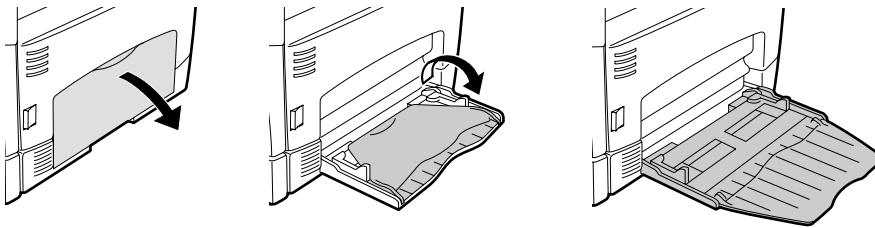

Note

To close the bypass tray, perform step 1 and then step 2 in the illustration and push the round projections at the right of the tray until the tray clicks into place.

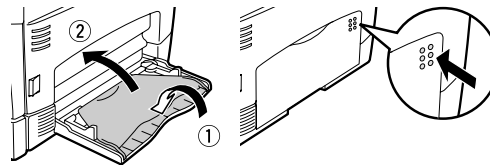

- 3 Set the paper guides to the copy paper width. Insert the copy paper (print face down) all the way into the bypass tray.



Note

- Paper must be fed narrow side into the feed slot.
- Transparency film, labels, and other special purpose papers must be fed individually.
- When copying onto transparency film, remove each copy promptly. Do not let copies stack up.
- When loading an envelope, make sure that it is straight and flat.

BYPASS FEED

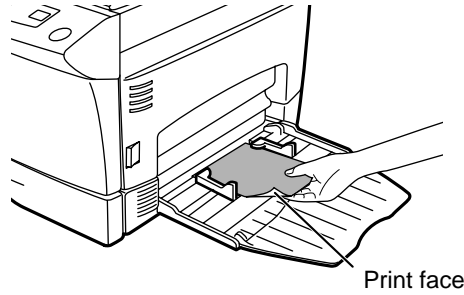
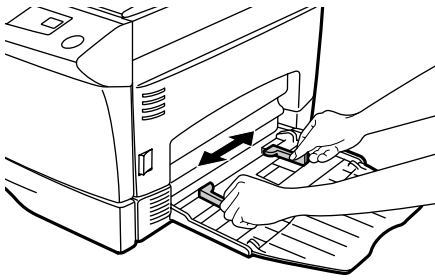

- 4** Press the tray select (⊞) key to select the bypass tray. Set the number of copies if using standard copy paper. Press the print (⏻) key.

2

Making copies

3

SPECIAL FUNCTIONS

DESCRIPTION OF SPECIAL FUNCTIONS

This chapter describes the special functions of this copier. Use these functions as needed.

Toner save mode

Reduces toner consumption by approximately 10%.

Power save modes (page 21)

The copier has two power save modes of operation: preheat mode and auto power shut-off mode.

- **Preheat mode**

When the copier enters the preheat mode, the power save (⊕) indicator will light up and other indicators will remain on or off as before. In this condition, the fuser in the copier is maintained at a lower heat level, thereby saving power. To copy from the preheat mode, make desired copier selections and press the print (⊕) key using the normal copying procedure.

- **Auto power shut-off mode**

When the copier enters the auto power shut-off mode, the power save (⊕) indicator will light up and other indicators will go out. The auto power shut-off mode saves more power than the preheat mode but requires a longer time before starting copying. To copy from the auto power shut-off mode, press the print (⊕) key. Then make desired copier selections and press the print (⊕) key using the normal copying procedure.

Auto clear (page 21)

The copier returns to the initial settings a preset amount of time after the last copy is made. This preset amount of time (auto clear time) can be changed.

Stream feeding mode (page 21)

For description of the stream feeding mode, see page 16.

TONER SAVE MODE

1

Press the exposure mode selector key to select the manual (1...5) mode.

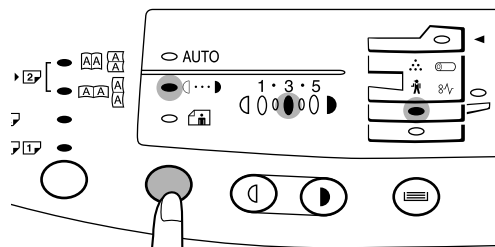

- 2 Press and hold down the exposure mode selector key for approximately 5 seconds. The manual (☐⋯▶) indicator will go out and the photo (📷) indicator will begin to blink. The exposure indicator marked "5" will light up, indicating the standard toner mode is active.

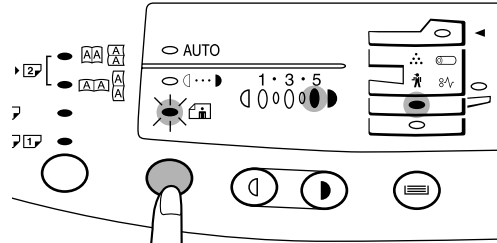

- 3 To enter the toner save mode, press the light (Ⓛ) key. The exposure indicator marked "1" will light up, indicating the toner save mode is selected.

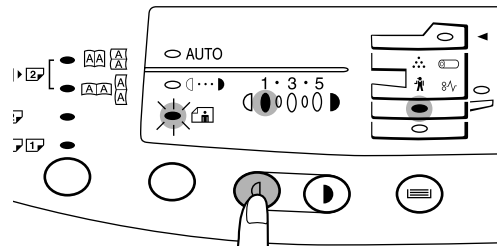

- 4 Press the exposure mode selector key twice. The photo (📷) indicator will stop blinking and the AUTO indicator will light up steadily. The toner save mode is now active.

 **Note** To return to the standard mode, repeat the procedure but use the dark (Ⓧ) key to select exposure level "5" in step 3.

3
Special functions



USER PROGRAMS (power save modes, auto clear time, stream feeding mode)

The user programs allow the parameters of certain functions to be set, changed, or cancelled as desired.

Setting the power save modes, auto clear time, and stream feeding mode

- 1 Press and hold down the light (Ⓛ) and dark (Ⓧ) keys simultaneously for more than 5 seconds until all the alarm indicators (🔊, ⚡, 📶, and 🚫) blink and "—" appears in the display.
- 2 Use the left copy quantity (⏪) key to select a user program number (1: auto clear time, 2: preheat mode, 3: auto power shut-off timer, 4: stream feeding mode, 5: auto power shut-off mode). The selected number will blink in the left side of the display.

USER PROGRAMS

- Press the print () key. The entered program number will be steadily lit and the currently selected parameter number for the program will blink on the right side of the display.
- Select the desired parameter using the right copy quantity () key. The entered parameter number will blink on the right of the display.

Program No.	Mode	Parameters		
1	Auto clear time	0 ⇨ OFF 3 ⇨ 90 sec.	1 ⇨ 30 sec. 4 ⇨ 120 sec.	* 2 ⇨ 60 sec. 5 ⇨ 10 sec.
2	Preheat mode	0 ⇨ 30 sec.	1 ⇨ 60 sec.	* 2 ⇨ 90 sec.
3	Auto power shut-off timer	0 ⇨ 2 min. 3 ⇨ 30 min.	* 1 ⇨ 5 min. 4 ⇨ 60 min.	2 ⇨ 15 min. 5 ⇨ 120 min.
4	Stream feeding mode	0 ⇨ OFF	* 1 ⇨ ON	
5	Auto power shut-off mode	0 ⇨ OFF	* 1 ⇨ ON	

Factory default settings are indicated with an asterisk (*).

- Press the print () key. The right-hand number in the display will be steadily lit and the entered value will be stored.





Note

To change the setting or to set another mode, press the clear () key. The copier will return to step 2.

- Press the light () or dark () key to return to the normal copy mode.

DISPLAYING TOTAL NUMBER OF COPIES

Use the following procedure to display the total number of copies.

- Press the clear () key to reset the display to zero.
- Press and hold down the clear () key for approximately 5 seconds. The total number of copies will appear in two steps, each with three digits.
Example: Total number of copies is 1,234.

 ⇨ 

4

SUPPLIES AND USER MAINTENANCE

This chapter describes how to replace the TD cartridge and the drum cartridge.



Caution

Be sure to use only genuine SHARP parts and supplies.

TD CARTRIDGE REPLACEMENT

The TD cartridge replacement required (∴) indicator will light up when toner is needed. If copying is continued while the ∴ indicator is lit, copies will gradually become lighter until the copier stops and the indicator begins blinking. Replace the old TD cartridge by following the procedure given below.



Note

- After the copier stops, it may be possible to make a few more copies by taking the TD cartridge out of the copier, shaking it horizontally, then reinstalling it. If copying is not possible after this operation, replace the TD cartridge.
- During a long copy run of a dark original, the ready (⊕) indicator may blink, the ∴ indicator light up, and the copier stop, even though toner is left. The copier will feed toner up to 2 minutes and then the ready (⊕) indicator will light up. Press the print (⊕) key to restart copying.

1

Ensure that the bypass tray is open and then open the side cover while pressing the side cover open button.

Then, push gently on both sides of the front cover to open the cover.

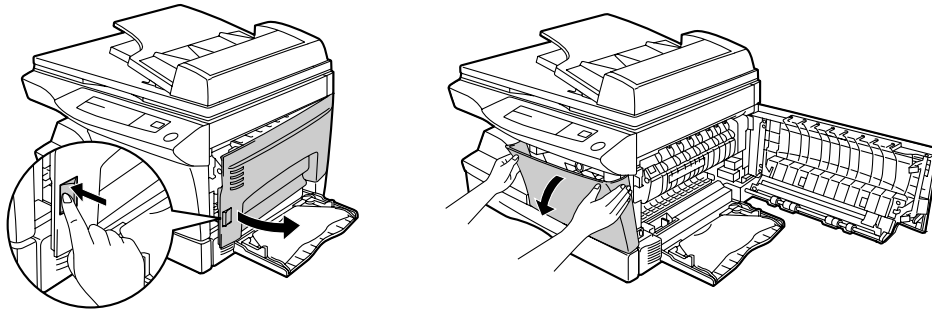

2

Gently pull the TD cartridge out while pressing the lock release button. Dispose of the old TD cartridge in accordance with local regulations.

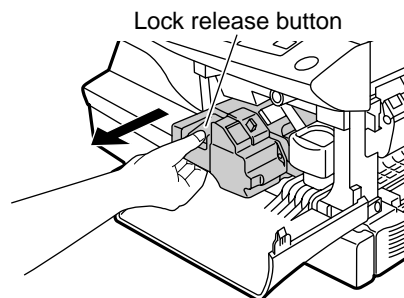

Lock release button

4

Supplies and user maintenance

TD CARTRIDGE REPLACEMENT

- 3** Remove the TD cartridge from the bag. Remove the protective paper. Hold the cartridge on both sides and shake it horizontally four or five times. Hold the tab of the protective cover and pull the tab to your side to remove the cover.

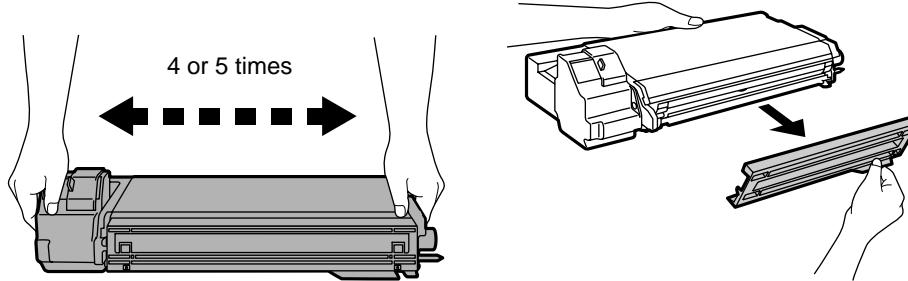

- 4** Gently insert the TD cartridge until it locks in place.

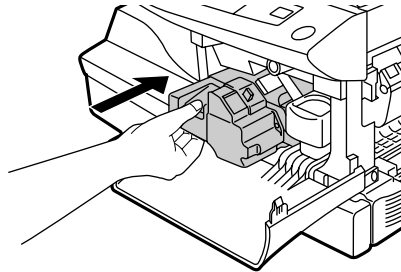

- 5** Close the front cover and then the side cover by pressing the round projections near the side cover open button. The \therefore indicator will go out and the ready (\odot) indicator will light up.



Note

When closing the covers, be sure to close the front cover securely and then close the side cover. If the covers are closed in the wrong order, the covers may be damaged.

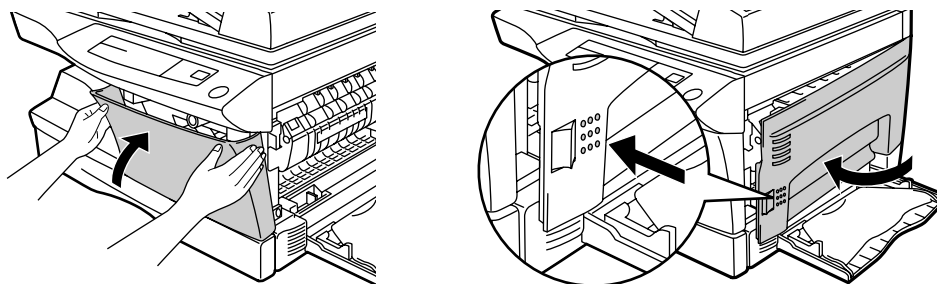

DRUM CARTRIDGE REPLACEMENT

The useful life of the drum cartridge is approximately 18,000 copies. When the internal counter reaches approximately 18,000 copies, the drum replacement required (☹) indicator will light up. When the indicator light up, replace the drum cartridge by following the procedure given below.



Caution

Do not remove the protective cover on the drum portion (black paper) of a new drum cartridge before use. The cover protects the drum against external light.

- 1** Ensure that the bypass tray is open and then open the side cover while pressing the side cover open button. Then, push gently on both sides of the front cover to open the cover.

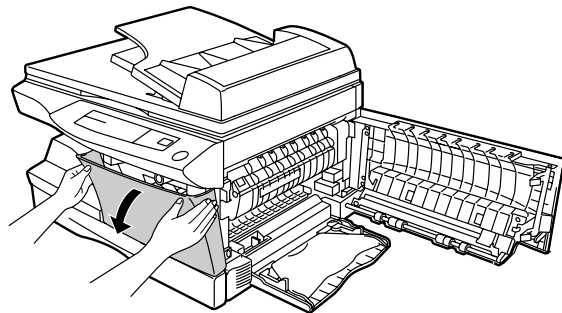
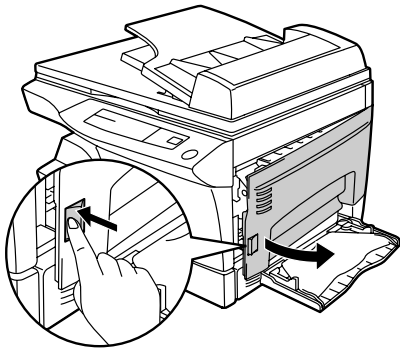

- 2** Gently pull the TD cartridge out while pressing the lock release button. To remove the TD cartridge, see page 23, step 2.

- 3** Hold the handle of the drum cartridge and gently pull the cartridge out. Dispose of the old drum cartridge in accordance with local regulations.

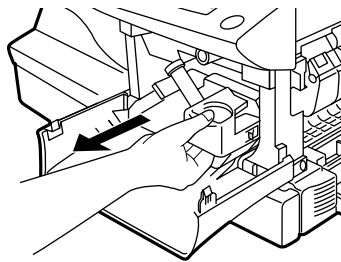

- 4** Remove the new drum cartridge from the protective bag and remove the protective cover from the cartridge. Then gently install the new drum cartridge.



Note

Do not touch the surface of the drum (green portion) of the cartridge. Doing so may cause smudges on the copies.

4

Supplies and user maintenance

DRUM CARTRIDGE REPLACEMENT

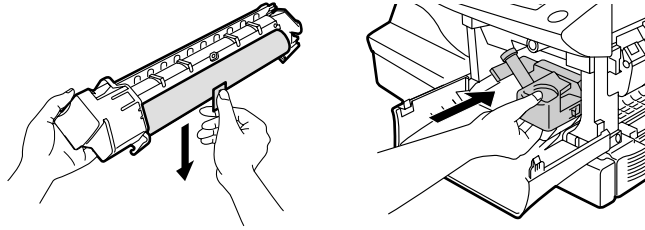

- 5** Gently install the TD cartridge. To install the TD cartridge, see page 23, **TD CARTRIDGE REPLACEMENT**.
- 6** Close the front cover and then the side cover by pressing the round projections near the side cover open button. The drum replacement required (Ⓞ) indicator will go out and the ready (Ⓢ) indicator will light up.



Caution

When closing the covers, be sure to close the front cover securely and then close the side cover. If the covers are closed in the wrong order, the covers may be damaged.

4

Supplies and user maintenance

Drum cartridge life

To find out how many more copies can be made before the 18,000 mark is reached, follow the procedure described below.

- 1** Press and hold down the light (Ⓛ) and dark (Ⓧ) keys simultaneously for more than 5 seconds until all the alarm indicators (Ⓞ, Ⓢ, Ⓡ, and Ⓣ) blink and “--” appears in the display.
- 2** Press and hold down the clear (Ⓢ) key for more than 5 seconds to find out how many more copies can be made.
Example: 500 copies can be made before the next drum cartridge replacement.

000 → 500

- 3** Press the light (Ⓛ) or dark (Ⓧ) key. The ready (Ⓢ) indicator will light up.

USER MAINTENANCE

Proper care is essential in order to get clean, sharp copies. Be sure to take a few minutes to regularly clean the copier.



Before cleaning, be sure to turn the power switch off and remove the power cord from the outlet.



Do not use thinner, benzene or other volatile cleaning agents. Doing so may cause deformation, discoloration, deterioration or malfunction.

Cabinet

Wipe the cabinet with a soft, clean cloth.

Original table and original cover

Stains on the glass, cover or RSPF roller will also be copied. Wipe the glass, cover and RSPF roller with a soft, clean cloth. If necessary, dampen the cloth with a glass cleaner.

Original table

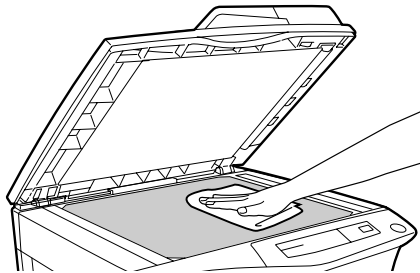

Original cover

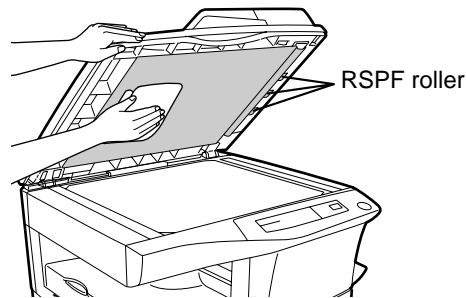

Transfer charger

If copies start becoming streaky or blotchy, the transfer charger may be dirty. Clean the charger using the following procedure.

- 1 Turn the power switch off.
- 2 Ensure that the bypass tray is open and then open the side cover while pressing the side cover open button.

USER MAINTENANCE

- 3 Take the charger cleaner out by holding the tab. Set the charger cleaner onto the right end of the transfer charger, gently slide the cleaner to the left end, and then remove it. Repeat this operation two or three times.



Caution

Slide the charger cleaner from the right end to the left end along the groove of the transfer charger. If the cleaner is stopped on the way, smudges on copies may occur.

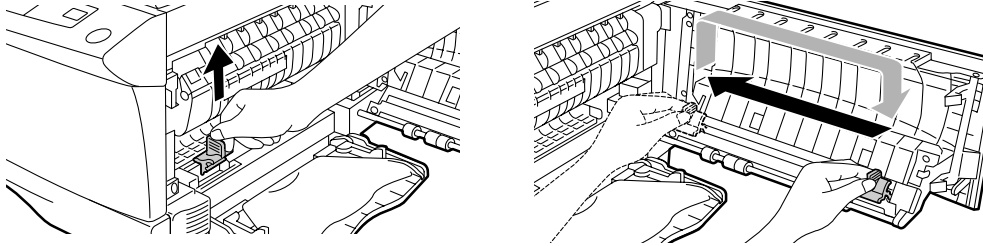

4

- 4 Return the charger cleaner to its original position. Close the side cover by pressing the round projections near the side cover open button.

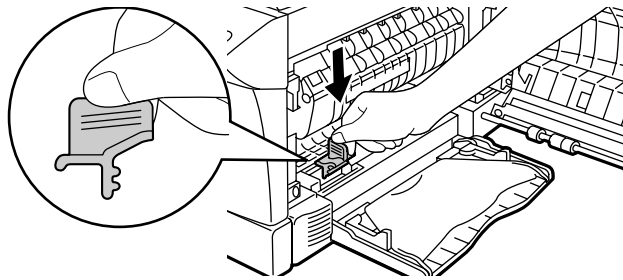

- 5 Turn the power switch on.

When copier is not in use

To prevent entry of dust and foreign matter, store the copier as follows.

- 1 Remove the power cord and secure the copier using tape (four locations).

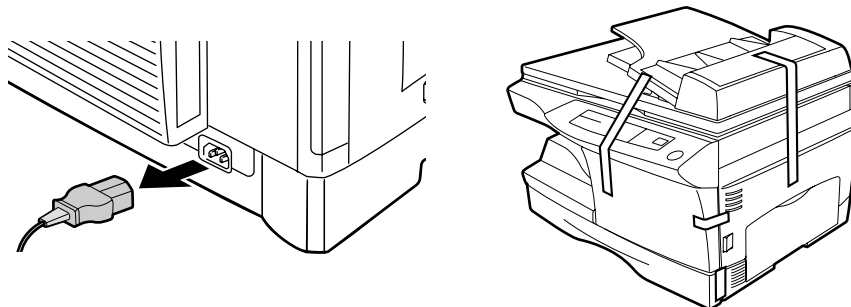

5 COPIER TROUBLE?

This chapter describes misfeed removal and troubleshooting.

MISFEED REMOVAL

When the misfeed (⚠) indicator blinks or **P** blinks in the display, the copier will stop because of a misfeed.

If a misfeed occurs when using the RSPF, a number may appear in the display after a minus sign. This indicates the number of the originals that must be returned to the document feeder tray after a misfeed. Return the required number of originals. Then this number will disappear when copying is resumed or the clear (Ⓢ) key is pressed.

When the RSPF misfeeds an original sheet, the copier will stop and the RSPF misfeed (⬅) indicator will blink, while the misfeed (⚠) indicator will remain off. For a misfeed of originals in the RSPF, see "**D Misfeed in the RSPF**" on page 32.

- 1 Ensure that the bypass tray is open and then open the side cover while pressing the side cover open button.

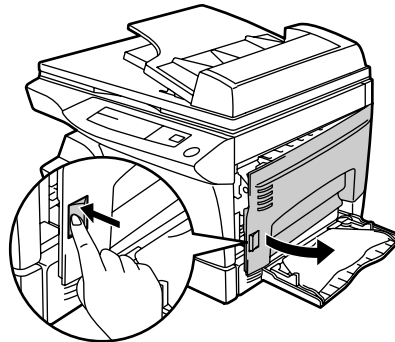

- 2 Check the misfeed location. Remove the misfed paper following the instructions for each location in the illustration below.

If **P** blinks in the display, proceed to "**A Misfeed in the paper feed area**". (p. 30)

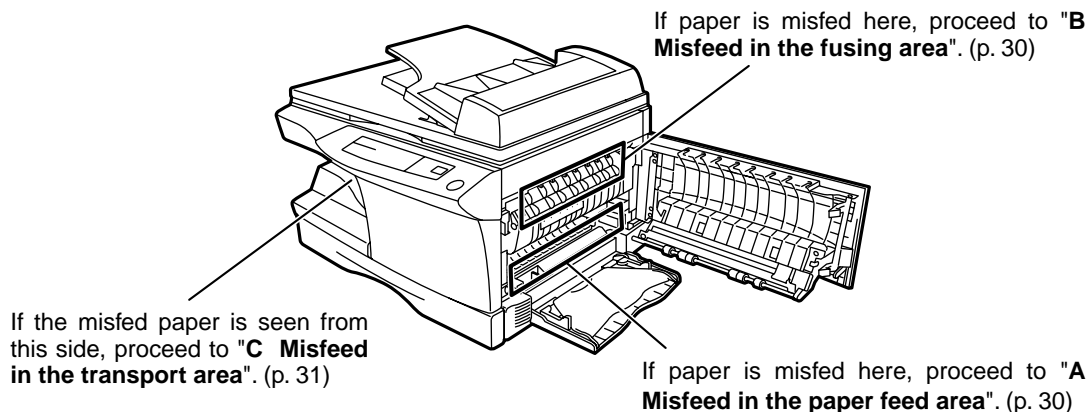

MISFEED REMOVAL

A Misfeed in the paper feed area

- 1 Gently remove the misfed paper from the paper feed area as shown in the illustration. When  blinks in the display and the misfed paper is not seen from the paper feed area, pull out the paper tray and remove the misfed paper. If the paper cannot be removed, proceed to “**B Misfeed in the fusing area**”.



Warning

The fusing unit is hot. Do not touch the fusing unit when removing misfed paper. Doing so may cause a burn or other injury.



Caution

- Do not touch the surface of the drum (green portion) of the drum cartridge when removing the misfed paper. Doing so may damage the drum and cause smudges on copies.
- If the paper has been fed through the bypass tray, do not remove the misfed paper through the bypass tray. Toner on the paper may stain the paper transport area, resulting in smudges on copies.

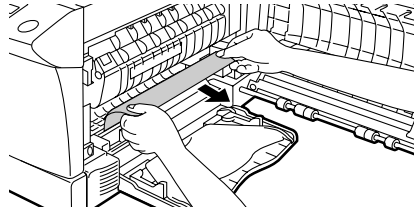

- 2 Close the side cover by pressing the round projections near the side cover open button. The misfeed (⊗) indicator will go out and the ready (⊕) indicator will light up.

B Misfeed in the fusing area

- 1 Lower the fusing unit release lever by rotating it all the way as shown in the illustration.



Note

While you are lowering the fusing unit release lever, it will not move smoothly at a location on the way. However, be sure to lower the lever by rotating it all the way to the location where it will not rotate as shown in the right illustration.

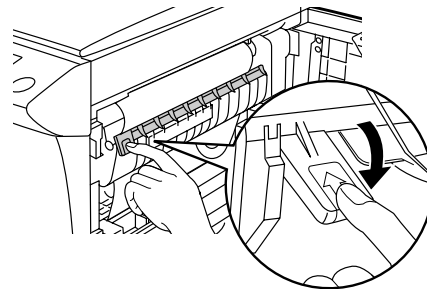
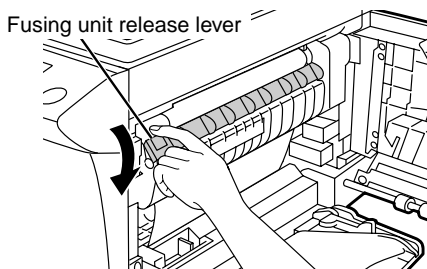

- 2 Gently remove the misfed paper from under the fusing unit as shown in the illustration. If the paper cannot be removed, proceed to “**C Misfeed in the transport area**”.



Warning

The fusing unit is hot. Do not touch the fusing unit when removing misfed paper. Doing so may cause a burn or other injury.

 **Caution**

- Do not touch the surface of the drum (green portion) of the drum cartridge when removing the misfed paper. Doing so may cause smudges on copies.
- Do not remove the misfed paper from above the fusing unit. Unfixed toner on the paper may stain the paper transport area, resulting in smudges on copies.

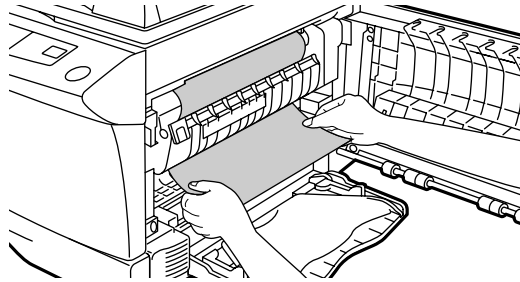

- 3** Raise the fusing unit release lever and then close the side cover by pressing the round projections near the side cover open button. The misfeed (⊗) indicator will go out and the ready (⊙) indicator will light up.

C Misfeed in the transport area

- 1** Lower the fusing unit release lever by rotating it all the way as shown in the illustration.

 **Note**

While you are lowering the fusing unit release lever, it will not move smoothly at a location on the way. However, be sure to lower the lever by rotating it all the way to the location where it will not rotate as shown in the right illustration.

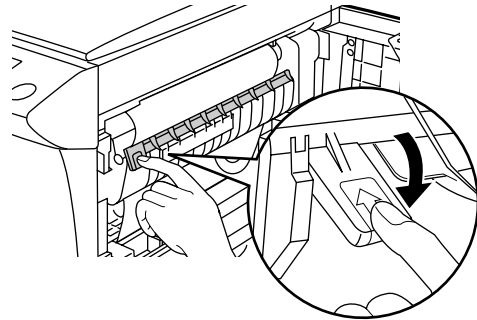
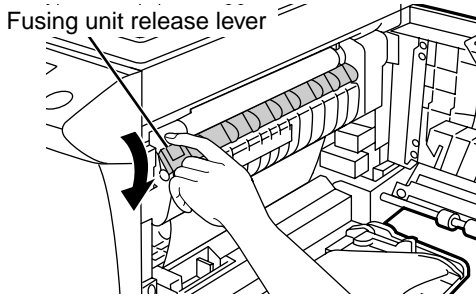

- 2** Push gently on both sides of the front cover to open the cover.

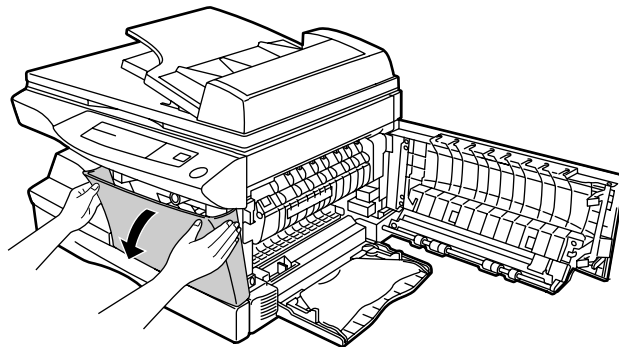

5

Copier trouble?

MISFEED REMOVAL

- 3 Rotate the feeding roller in the direction of the arrow and gently remove the misfed paper from the exit area.

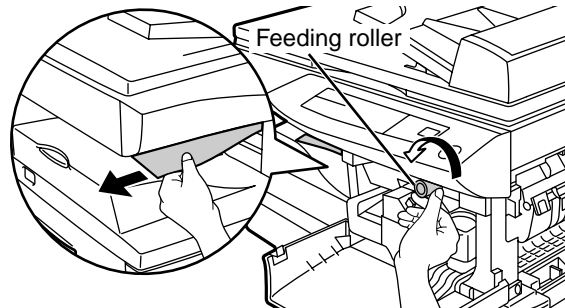

- 4 Raise the fusing unit release lever, close the front cover and then close the side cover by pressing the round projections near the side cover open button. The misfeed (⚠) indicator will go out and the ready (Ⓜ) indicator will light up.



Caution

When closing the covers, be sure to close the front cover securely and then close the side cover. If the covers are closed in the wrong order, the covers may be damaged.

5

Copier trouble?

D Misfeed in the RSPF

An original misfeed may occur at one of three locations: if the misfed original is seen from the document feeder tray, (A) in the document feeder tray; if the misfed original is not seen from the document feeder tray, (B) in the exit area or (C) under the feeding roller. Remove the misfed original following the instructions for each location.

- (A) Open the feeding roller cover and pull the original gently to the left and out from the document feeder tray. Close the feeding roller cover. Open and close the original cover to clear the RSPF misfeed (⚠) indicator. If the misfed original cannot be easily removed, proceed to (C).

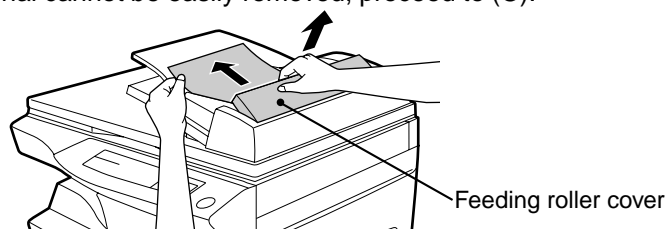

- (B) Open the original cover and rotate the roller rotating knob to remove the misfed original from the exit area. If the misfed original cannot be easily removed, proceed to (C).

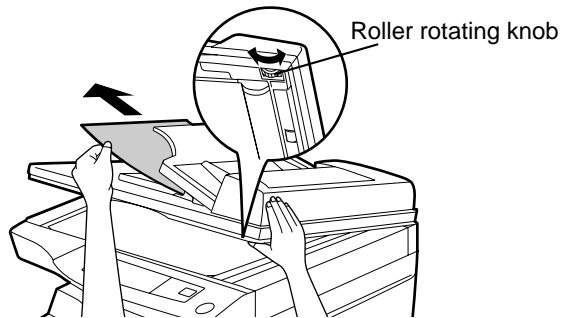

With the RSPF, pull out the reversing tray to remove the misfed original.



With the RSPF, after removing the misfed original from the exit area, be sure to insert the reversing tray into the exit area until it locks in place.

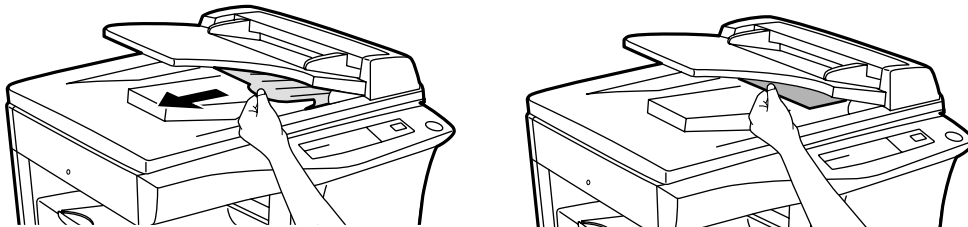

(C) If the original does not move easily into the exit area remove it in the direction of the arrow while rotating the knob.

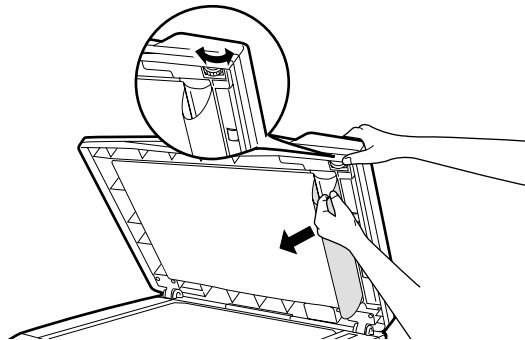

A number may appear in the display after a minus sign, indicating the number of the originals that must be returned to the document feeder tray. Clear the misfeed and return the required number of originals. Then press the print (Ⓢ) key to resume copying.

MAINTENANCE REQUIRED

When  indicator lights up, service by an authorised SHARP service technician is required. Contact your SHARP dealer as soon as possible.

5

Copier trouble?

TROUBLESHOOTING

If any problem occurs, check the list below before contacting your SHARP dealer.

Problem	Possible cause	Solution	See page:
Copier does not operate.	Copier plugged in?	Plug the copier into a grounded outlet.	–
	Power switch on?	Turn the power switch on.	13
	Side cover closed securely?	Gently close the side cover.	–
	Front cover closed?	Gently close the front cover and then close the side cover.	–
Blank copies	Is the original placed face down on the original table or face up in the RSPF?	Place the original face down on the original table or face up in the RSPF.	14
Power save (⏻) indicator on.	Is the copier in the preheat mode?	Press any key to cancel the preheat mode.	20
	Is the copier in the auto power shut-off mode?	Press the print (Ⓞ) key to cancel the auto power shut-off mode.	20
Copies are too dark or too light.	Is original image too dark or too light?	Adjust the exposure manually.	16
	Is the copier in the automatic exposure mode?	Adjust the automatic exposure level.	37
	Is the copier in the photo exposure mode?	Cancel the photo exposure mode.	16
Dust, dirt, smudges appear on copies.	Original table or original cover dirty?	Clean regularly.	27
	Original smudged or blotchy?	Use a clean original.	–
Striped copies	Is transfer charger clean?	Clean the transfer charger.	27
Paper misfeeds frequently.	Non-standard paper used?	Use standard paper. If using special papers, feed the paper through the bypass tray.	40
	Paper curled or damp?	Store copy paper flat in the wrapper in a dry location.	–
	Pieces of paper inside copier?	Remove all pieces of misfed paper.	29
	Paper guides in the paper tray not set properly?	Set the guides properly depending on the paper size.	10
	Too much paper in the paper tray or bypass tray?	Remove excessive paper from the tray.	10
Images rub off the copy easily.	Is the copy paper too heavy?	Use copy paper within the specified range.	40
	Paper damp?	Replace with dry copy paper. If the copier is not used for long time, remove the paper from the paper tray and store it in its wrapper in a dry location.	41

STATUS INDICATORS

When the following indicators light up or blink on the operation panel or the following alphanumeric codes appear in the display, solve the problem immediately referring to both the table below and the relevant page.



Caution

Be sure to use only genuine SHARP parts and supplies.

Indication			Cause and remedy	See page:
	Drum replacement required indicator	Steadily lit	Drum cartridge must be replaced. Replace it with a new one.	25
	TD cartridge replacement required indicator	Steadily lit	Replacement of TD cartridge will be needed soon. Obtain a new cartridge.	–
		Blinking	TD cartridge must be replaced. Replace it with a new one.	23
	Misfeed indicator	Blinking	A misfeed has occurred. Remove the misfed paper referring to the description of "Misfeed removal."	29
			The lower side cover may be open. If so, close it.	–
	Maintenance indicator	Steadily lit	Service by an authorised SHARP service technician is required.	34
	RSPF misfeed indicator	Blinking	An original misfeed has occurred in the RSPF. Remove the misfed originals referring to the description of "Misfeed in the RSPF".	32
	The paper tray indicator is blinking.		The paper tray is not installed properly. Push the tray into the copier securely.	–
	"CH" is blinking in the display.		The TD cartridge is not installed. Check if the cartridge is installed.	23
	"CH" is steadily lit in the display.		Side cover is open. Close the side cover securely by pressing the round projections near the side cover open button.	–
	"P" is blinking in the display.		Paper tray or bypass tray is empty. Load copy paper.	10
			A misfeed has occurred in the paper tray or bypass tray. Remove the misfed paper.	29
	A letter and a number appear alternately.		The copier will not function. Turn the power switch off, remove the power cord from the outlet, and contact your SHARP dealer.	–

5

Copier trouble?

AUTOMATIC EXPOSURE ADJUSTMENT

The automatic exposure level can be adjusted to suit your copying needs. This level is set for copying from the original table and copying from the RSPF respectively.

- 1** When adjusting the automatic exposure level for copying from the RSPF, place an original in the document feeder tray and make sure that the RSPF (☞) indicator lights up.
When adjusting the level for copying from the original table, make sure that no original is left in the document feeder tray.

- 2** Press the exposure mode selector key to select the photo (📷) mode.

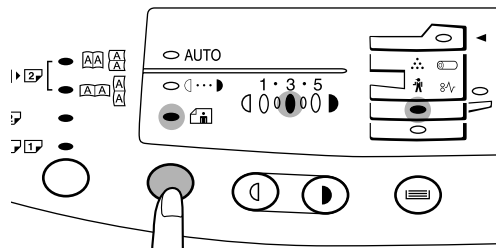

- 3** Press and hold down the exposure mode selector key for approximately 5 seconds. The photo (📷) indicator will go out and the AUTO indicator will begin to blink. One or two exposure indicators corresponding to the automatic exposure level which has been selected will light up.

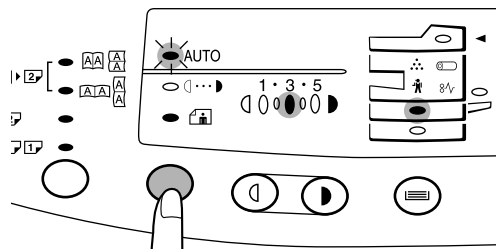

- 4** Press the light (☞) or dark (☜) key to lighten or darken the automatic exposure level as desired.
If exposure level 2 is selected, the two left-handmost indicators for that level will light up simultaneously. Also, if level 4 is selected, the two right-handmost indicators for that level will light up simultaneously.

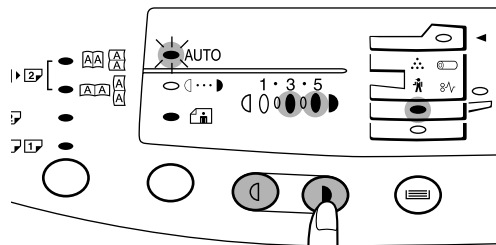

- 5** Press the exposure selector key. The AUTO indicator will stop blinking and light up steadily.



This automatic exposure level will remain in effect until you change it again by this procedure.

5

Copier trouble?

6 APPENDIX

SPECIFICATIONS

Type	Digital laser copier, desk-top type
Copy system	Dry, electrostatic transfer
Originals	Sheets, bound documents
Original size	Max. B4 (257 mm x 364 mm) (10" x 14") ((A5 to B4 for RSPF) (5-1/2" x 8-1/2" to 10" x 14" for RSPF))
Copy sizes	A6 to A4 (105 mm x 148.5 mm to 210 mm x 297 mm) (3-1/2" x 5-1/2" to 8-1/2" x 14") (Feed copy paper lengthwise only.) Image loss: Max. 4 mm (5/32") (leading and trailing edges) Max. 4.5 mm (11/64") (along the other edges in totals) Max. 6 mm (15/64") (the trailing edge of the second copy of two-sided copying)
Copy speed (one-sided copying)	15 copies/min.
Continuous copying	Max. 99 copies; subtractive counter
First-copy time (Approximately)	9.6 sec. (normal copying mode)
Copy ratio	Variable: 50% to 200% in 1% increments (total 151 steps) Fixed: 50%, 70%, 81%, 100%, 141%, 200% (50%, 64%, 78%, 100%, 129%, 200%)
Exposure system	Original table: Moving optical source, slit exposure (stationary platen) with automatic exposure RSPF: Moving original
Copy paper feed	One paper tray with automatic feed (250 sheets); one bypass tray with 50-sheet automatic feed capability
Fusing system	Heat rollers
Development system	Magnetic brush development
Light source	Xenon lamp
Resolution	Scan: 400 dpi Output: 600 dpi
Memory	6 MB

SPECIFICATIONS

Power supply	240V +6%, -10% in 240V power supply regions or local voltage $\pm 10\%$ in other regions (For this copier's power supply requirements, see the name plate located on the back of the unit.)
Power consumption	1,000 W
Overall dimensions	809 mm (W) x 483 mm (D) (31.9" (W) x 19" (D))
Weight (Approximately)	23 kg (50.7 lbs.) TD and drum cartridges included
Copier dimensions	518 mm (W) x 483 mm (D) x 379 mm (H) (20.4" (W) x 19" (D) x 15" (H))
Operating conditions	Temperature: 10°C to 30°C (50°F to 86°F) Humidity: 20% to 85%
Noise level	Sound Power Level L_{WA} Copying: 71 [dB (A)], Standby: Background noise level Sound Pressure Level L_{PA} (bystander positions) Copying: 40 [dB (A)], Standby: Background noise level Noise emission measurement in accordance with ISO 7779.
Optional equipment	GDI expansion kit (AR-PG1) PCL expansion kit (AR-PB9) 250-sheet paper feed unit (AR-DE9)

First-copy time may differ depending on operating conditions, such as power-supply voltage and room temperature.



Note

As a part of our policy of continuous improvement, SHARP reserves the right to make design and specification changes for product improvement without prior notice. The performance specification figures indicated are nominal values of production units. There may be some deviations from these values in individual units.

SUPPLIES

Types and sizes of copy paper

For best results, use only paper recommended by SHARP.

Type of paper feeding	Type of media		Size	Weight
Paper tray	Standard paper		A5 (148.5mm x 210mm) A4 (210mm x 297mm) B5 (182mm x 257mm) Letter (8-1/2" x 11") Legal (8-1/2" x 14") Invoice (5-1/2" x 8-1/2")	56 to 80 g/m ² (15 lbs. to 21 lbs.)
Bypass tray	Standard paper and thick paper		A6 (105mm x 148.5mm) A5 (148.5mm x 210mm) A4 (210mm x 297mm) B5 (182mm x 257mm) Letter (8-1/2" x 11") Legal (8-1/2" x 14") Invoice (5-1/2" x 8-1/2")	52 to 130 g/m ² (14 lbs. to 34.5 lbs.)**
	Special media	Transparency film	A4 (210mm x 297mm) Letter (8-1/2" x 11")	
		Envelope*	International DL (110mm x 220mm) International C5 (162mm x 229mm) Commercial 10 (4-1/8" x 9-1/2") Monarch (3-7/8" x 7-1/2")	

* Do not use envelopes that have metal clasps, plastic snappers, string closures, windows, linings, self-adhesive, patches or synthetic materials. These will cause physical damage to the copier.

** For paper weighing from 104 to 130 g/m² (28 to 34.5 lbs.), A4 (8-1/2" x 11") is the maximum size that can be fed through the bypass tray.

- Special papers such as transparency film and labels must be fed one sheet at a time through the bypass tray.



Caution

Be sure to use only genuine SHARP parts and supplies.



For best copying results, be sure to use only SHARP Genuine Supplies which are designed, engineered, and tested to maximize the life and performance of SHARP copiers. Look for the Genuine Supplies label on the toner package.

Proper storage

1. Store the supplies in a location that is:
 - clean and dry,
 - at a stable temperature,
 - not exposed to direct sunlight.
2. Store copy paper in the wrapper and lying flat.
 - Paper stored out of the wrapper or in packages standing on end may curl or get damp, resulting in paper misfeeds.

7

OPTIONAL EQUIPMENT

SYSTEM CONFIGURATION

A number of options are available for the copier which allow you to configure a copier system to meet your particular needs. The options include the following.

GDI expansion kit (AR-PG1)*
PCL expansion kit (AR-PB9)*

* This option is not used for the copier operation. For description of this option, see the separate manual.

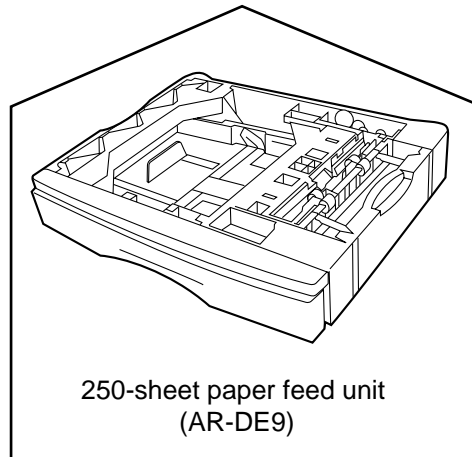
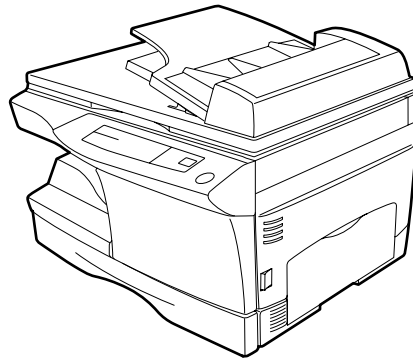

250-sheet paper feed unit
(AR-DE9)



Note

The GDI expansion kit (AR-PG1) and PCL expansion kit (AR-PB9) cannot be used together at a time (exclusive combination).

250-SHEET PAPER FEED UNIT (AR-DE9)

The paper feed unit provides the convenience of increased paper capacity for the copier and a greater choice of paper sizes readily available for copying.

Part names

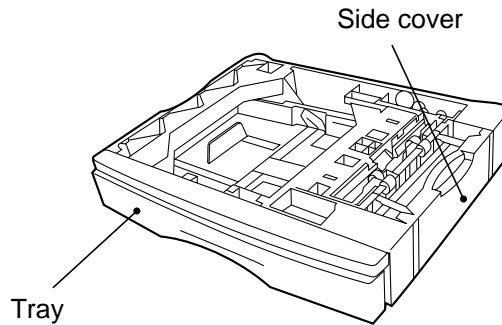



Loading copy paper

The method of loading copy paper for the paper tray of the paper feed unit is the same as for the paper tray in the copier. See page 10.

The method of changing the copy paper size is also the same for the paper tray in the copier. See page 10.

Misfeed removal

The copier will stop when a misfeed occurs. The misfeed (P) indicator blinks or  blinks in the display.

- 1 Open the lower side cover (under the bypass tray) and remove the misfed paper. If  blinks and the misfed paper is not seen from the area of the lower side cover, pull out the lower paper tray and remove the misfed paper. Then close the lower paper tray.

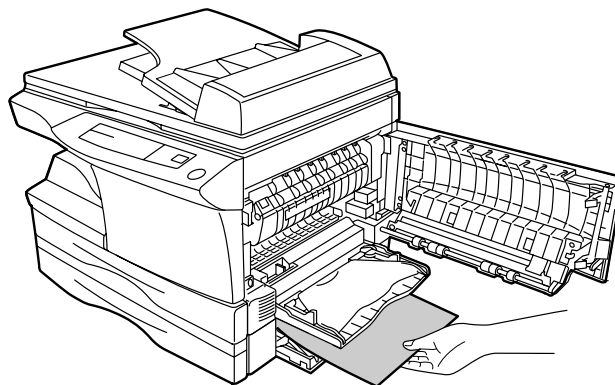

7

Optional equipment

250-SHEET PAPER FEED UNIT (AR-DE9)

- 2 Close the lower side cover.
- 3 Close the side cover by pressing the round projections near the side cover open button. The misfeed (⊗) indicator will go out and the ready (⊕) indicator will light up.

Specifications

Copy paper size	A5 to B4 (5-1/2" x 8-1/2" to 8-1/2" x 14")
Paper weight	56 to 80 g/m ² (15 lbs. to 21 lbs.)
Paper capacity	One paper tray with capacity for 250 sheets of 80 g/m ² (21 lb.) bond paper
Weight	Approx. 3 kg (6.6 lbs.)
Dimensions	498 mm (W) x 395 mm (D) x 88 mm (H) (19.6" (W) x 15.6" (D) x 3.5" (H))
Power supply	Drawn from the copier



As a part of our policy of continuous improvement, SHARP reserves the right to make design and specification changes for product improvement without prior notice. The performance specification figures indicated are nominal values of production units. There may be some deviations from these values in individual units.

7

Optional equipment

INDEX

A

- Auto clear 20, 21
- Automatic exposure adjustment 37
- Auto power shut-off mode 20, 21

B

- Bypass tray 18

C

- Cautions 4
- Cautions on handling 9
- Charger cleaner 28
- Copier trouble? 29
- Copying
 - normal 12
 - reduction/enlargement 17
 - through bypass tray 18
 - two-sided 12
- Copy paper 40
- Copy quantity 15
- Copy ratio 17

D

- Dark key 16
- Document feeder tray 13
- Drum cartridge
 - indicator 7, 36
 - replacement 25

E

- Enlargement 17
- Exposure adjustment 16

F

- Features 5
- Fixed copy ratio 17
- Fusing unit release lever 6, 30, 31

G

- GDI expansion kit (AR-PG1) 42

I

- Installation
 - location 8

L

- Light key 16
- Loading copy paper 10

M

- Maintenance
 - user maintenance 27
 - maintenance required indicator 34
- Manual exposure 16
- Manual feeding 18
- Misfeed removal
 - fusing area 30
 - lower paper feed area 43
 - paper feed area 30
 - RSPF 32
 - transport area 31

N

- Names
 - operation panel 7
 - part 6

O

- ON LINE indicator 7
- Operation panel
 - part names 7
- Options 42
- Original cover 6
- Original guides 6, 13
- Original table 6, 14

P

- Paper
 - loading 10
 - special 40
 - specifications 40
- Paper feed area 30
- Paper output tray 6
- Paper output tray extension 6, 12
- Paper size 40
- Paper transport area 31
- Paper tray 6
- Part names 6
- PCL expansion kit (AR-PB9) 39, 42
- Photo mode 7, 16
- Power on 13
- Power save modes 20, 21
- Power switch 6, 13
- Preheat mode 20, 21
- Print key 15

INDEX

R

Ready indicator	7
Reduction	17
Replacement	
– drum cartridge	25
– TD cartridge	23
Reversing single pass feeder (RSPF)	12

S

Special paper	40
Specifications	
– copier	38
– paper	40
Status indicators	36
– storage of supply	41

T

TD cartridge	
– indicator	7, 36
– replacement	23
Toner save mode	20
Total number of copies	22
Transfer charger	6, 27
Troubleshooting	35
Two-sided copying	12

U

User maintenance	
– cabinet	27
– original cover	27
– original table	27
– transfer charger	27

Z

Zoom	17
------------	----

S H A R P

Date Issued: Aug. 1, 1999

MATERIAL SAFETY DATA SHEET

MSDS No. F-00971

Section 1. Product Identification

Product:

AR-150TD/TD-J/DC/MI/MI-J/LI/CI/MT/MT-J/LT/CT (Black Toner)

Section 2. Supplier's Name and Address

Sharp Corporation

22-22 Nagaïke-cho, Abeno-ku, Osaka, Japan

Local suppliers are listed below. Please contact the nearest supplier for additional information.

(Country)	(Name and Telephone Number)
U.S.A.	Sharp Electronics Corporation Telephone number for information: 1-800-237-4277 Emergency telephone number: 1-800-255-3924
Canada	Sharp Electronics of Canada Ltd. Telephone number for information: 905-890-2100 Emergency telephone number: 1-800-255-3924
United Kingdom	Sharp Electronics (U.K.) Ltd. Telephone number for information: 01923-474013

Section 3. Ingredients

Ingredients	CAS No.	Proportion	OSHA PEL	ACGIH TLV	Other Limits
Styrene-Acrylate copolymer	29497-14-1	> 88 %	Not listed	Not listed	None
Carbon black	1333-86-4	< 6.0%	3.5mg/m ³	3.5mg/m ³	None
Iron oxide	1309-38-2	< 4.5%	Not listed	Not listed	None
Metal Complex dye	{ 109125-51-1 109125-50-0 84179-66-8	< 1.5%	0.5mg/m ³	0.5mg/m ³	None

Section 4. Hazardous Identification (Emergency Overview)

Toner is a fine, black powder possessing no immediate hazard. There are no anticipated carcinogenic effects from exposure based on animal tests performed using toner. When used as intended according to instructions, studies do not indicate any symptoms of fibrosis will occur.

Section 5. Health Hazard Data

Route(s) of Entry:	Inhalation?	Skin?	Ingestion?
	Yes	No	Possible but very unusual.
Health Hazards:	Acute oral toxicity ----- LDLO of this toner is over 2,000mg/kg. Mutagenicity ----- The result of Ames test is negative.		
Carcinogenicity:	In 1996 the IARC reevaluated carbon black as a Group 2B carcinogen (possible human carcinogen). This classification is given to chemicals for which there is inadequate human evidence, but sufficient animal evidence on which to base an opinion of carcinogenicity. The classification is based upon the development of lung tumors in rats receiving chronic inhalation exposures to free carbon black at levels that induce particle overload of the lung. Studies performed in animal models other than rats did not show any association between carbon black and lung tumors. Moreover, a two-year cancer bioassay using a typical toner preparation containing carbon black demonstrated no association between toner exposure and tumor development in rats.		
Chronic Effect:	In a study in rats of chronic inhalation exposure to a typical toner, a mild to moderate degree of lung fibrosis was observed in 92% of the rats in the high concentration (16mg/m ³) exposure group, and a minimal to mild degree of fibrosis was noted in 22% of the animals in the middle (4mg/m ³) exposure group, but no pulmonary change was reported in the lowest (1mg/m ³) exposure group, the most relevant level to potential human exposures.		
Signs and Symptoms of Exposure:	Minimal irritation to respiratory tract may occur as with exposure to any non-toxic dust.		
Medical Conditions Generally Aggravated by Exposure:	None		
Emergency and First Aid Procedures:	Inhalation; Remove to fresh air. If effects occur, consult medical personnel. Eye; In case of contact, immediately flush eyes with water for 15 minutes.		

Section 6. Physical Chemical Characteristics

Boiling / Melting Point:	Not applicable	Specific Gravity:	1.1
Vapor Pressure:	Not applicable	Solubility in Water:	Negligible
Vapor Density:	Not applicable	PH:	Not applicable
Evaporation Rate:	Not applicable	Viscosity:	Not applicable
Appearance:	Fine powder	Color:	Black
Odor:	Odorless		

Section 7. Fire and Explosion Data

Flash Point (Method Used):	Not applicable
Ignition Temperature:	>350°C
Flammable Limits:	(LEL); Not applicable (UEL); Not applicable
Extinguishing Media:	CO ₂ , dry chemical, foam or water
Special Fire Fighting Procedure:	None
Unusual Fire and Explosion Hazard:	This material has no unusual fire or explosion hazards.
Sensitivity to Mechanical Impact:	None
Sensitivity to Static Charge:	None

Section 8. Reactivity Data

Stability:	Stable
Incompatibility (Material to Avoid):	None
Hazardous Decomposition:	CO and NO _x
Hazardous Polymerization:	Will not occur.

Section 9. Precautions for Safe Handling and Use

Personal Protection Information (Respiratory, Eye Protection and Protective Glove):	
Use of a dust mask is recommended when handling a large quantity of toner or during long term exposure, as with any non-toxic dust.	
Engineering Control / Ventilation:	Not required.
Work / Hygienic Practice:	Inhalation should be minimized as with any non-toxic dust.
Steps to be taken in case of Spill or Leak:	Sweep up or clean up with vacuum cleaner.
Waste Disposal Method:	Waste material may be dumped or incinerated under conditions which meet all federal, state and local environmental regulations.

Section 10. Regulatory Information

NFPA Rating (U.S.A.):	Health = 1	Flammability = 1	Reactivity = 0
WHMIS Legislation (Canada):	This product is not a controlled product.		
Transport Information:	This product is not a hazardous material.		
UN No.:	None allocated.		

Section 11. Other Information

References: IARC (1996) IARC Monographs on the Evaluation of the Carcinogenic Risk of Chemicals to Humans, Vol. 65, Printing Process and Printing inks, Carbon Black and Some Nitro Compounds, Lyon, pp-149-261
H. Muhle, B. Bellmann, O. Creutzenberg, C. Dasenbrock, H. Ernst, R. Kilpper, J. C. MacKenzie, P. Morrow, U. Mohr, S. Takenaka, and R. Mermelstein (1991) Pulmonary Response to Toner upon Chronic Inhalation Exposure in Rats. Fundamental and Applied Toxicology 17, pp. 280-299

S H A R P

Date Issued :Aug. 1, 1999

MATERIAL SAFETY DATA SHEET

MSDS No. F-30971

Section 1. Product Identification

Product

AR-150TD/TD-J/DC/MI/MI-J/LI/CI (Black Developer)

Section 2. Supplier's Name and Address

Sharp Corporation

22-22 Nagaike-cho, Abeno-ku, Osaka, Japan

Local suppliers are listed below. Please contact the nearest supplier for additional information.

(Country)	(Name and Telephone Number)
U.S.A.	Sharp Electronics Corporation Telephone number for information: 1-800-237-4277 Emergency telephone number: 1-800-255-3924
Canada	Sharp Electronics of Canada Ltd. Telephone number for information: 905-890-2100 Emergency telephone number: 1-800-255-3924
United Kingdom	Sharp Electronics (U.K.) Ltd. Telephone number for information: 01923-474013

Section 3. Ingredients

Ingredients	CAS No.	Proportion	OSHA PEL	ACGIH TLV	Other Limits
Iron powder	7439-89-6	> 92.5%	Not listed	Not listed	None
Styrene-Acrylate copolymer	29497-14-1	< 7.0%	Not listed	Not listed	None
Carbon black	1333-86-4	< 0.5%	3.5mg/m ³	3.5mg/m ³	None

Section 4. Hazardous Identification (Emergency Overview)

Developer is a black powder containing small amounts of toner, and possessing no immediate hazard. There are no anticipated carcinogenic effects from exposure based on animal tests performed using toner.

Section 5. Health Hazard Data

Route(s) of Entry:	Inhalation?	Skin?	Ingestion?
	No	No	Possible but very unusual.
Health Hazards:	Acute oral toxicity -----	LDL0 of this toner which is included in this developer is over 2,000mg/kg.	
	Mutagenicity -----	The toner, which is included in this developer, has been tested on Ames test. The result is negative.	
Carcinogenicity:	In 1996 the IARC reevaluated carbon black as a Group 2B carcinogen (possible human carcinogen). This classification is given to chemicals for which there is inadequate human evidence, but sufficient animal evidence on which to base an opinion of carcinogenicity. The classification is based upon the development of lung tumors in rats receiving chronic inhalation exposures to free carbon black at levels that induce particle overload of the lung. Studies performed in animal models other than rats did not show any association between carbon black and lung tumors. While there have been no studies to date using developer, a two-year cancer bioassay using a typical toner preparation containing carbon black (a small amount of toner is included in the developer mixture) demonstrated no association between toner exposure and tumor development in rats.		
Signs and Symptoms of Exposure:	Minimal irritation to respiratory tract may occur as with exposure to any non-toxic dust.		
Medical Conditions Generally Aggravated by Exposure:	None		
Emergency and First Aid Procedures:			
	Inhalation;	Remove to fresh air. If effects occur, consult medical personnel.	
	Eye;	In case of contact, immediately flush eyes with water for 15 minutes.	

Section 6. Physical Chemical Characteristics

Boiling / Melting Point:	Not applicable	Specific Gravity:	about 7.3
Vapor Pressure:	Not applicable	Solubility in Water:	Negligible
Vapor Density:	Not applicable	PH:	Not applicable
Evaporation Rate:	Not applicable	Viscosity:	Not applicable
Appearance:	Fine powder	Color:	Black
Odor:	Odorless		

Section 7. Fire and Explosion Data

Flash Point (Method Used):	Not applicable
Ignition Temperature:	>350°C
Flammable Limits:	(LEL); Not applicable (UEL); Not applicable
Extinguishing Media:	CO ₂ , dry chemical, foam or water
Special Fire Fighting Procedure:	None
Unusual Fire and Explosion Hazard:	This material has no unusual fire or explosion hazards.
Sensitivity to Mechanical Impact:	None
Sensitivity to Static Charge:	None

Section 8. Reactivity Data

Stability:	Stable
Incompatibility (Material to Avoid):	None
Hazardous Decomposition:	CO and NO _x
Hazardous Polymerization:	Will not occur.

Section 9. Precautions for Safe Handling and Use

Personal Protection Information (Respiratory, Eye Protection and Protective Glove):	
	None required under normal use.
Engineering Control / Ventilation:	Not required.
Work / Hygienic Practice:	Not required.
Steps to be taken in case of Spill or Leak:	Sweep up or clean up with vacuum cleaner.
Waste Disposal Method:	Waste material may be dumped or incinerated under conditions which meet all federal, state and local environmental regulations.

Section 10. Regulatory Information

NFPA Rating (U.S.A.):	Health = 1	Flammability = 1	Reactivity = 0
WHMIS Legislation (Canada):	This product is not a controlled product.		
Transport Information:	This product is not a hazardous material.		
UN No.:	None allocated.		

Section 11. Other Information

References: IARC (1996) IARC Monographs on the Evaluation of the Carcinogenic Risk of Chemicals to Humans, Vol. 65, Printing Process and Printing inks, Carbon Black and Some Nitro Compounds, Lyon, pp-149-261
H. Muhle, B. Bellmann, O. Creutzenberg, C. Dasenbrock, H. Ernst, R. Kilpper, J. C. MacKenzie, P. Morrow, U. Mohr, S. Takenaka, and R. Mermelstein (1991) Pulmonary Response to Toner upon Chronic Inhalation Exposure in Rats. Fundamental and Applied Toxicology 17, pp. 280-299

MEMO

MEMO

In some areas, the "POWER" switch positions are marked "I" and "O" on the copier instead of "ON" and "OFF".

The symbol "O" denotes the copier is not completely de-energized but in a stand-by condition at this "POWER" switch position.

If your copier is so marked, please read "I" for "ON" and "O" for "OFF".

Caution!

For a complete electrical disconnection, pull out the main plug.

The socket-outlet shall be installed near the equipment and shall be easily accessible.

This equipment complies with the requirements of Directives 89/336/EEC and 73/23/EEC as amended by 93/68/EEC.

Dieses Gerät entspricht den Anforderungen der EG-Richtlinien 89/336/EWG und 73/23/EWG mit Änderung 93/68/EWG.

Ce matériel répond aux exigences contenues dans les directives 89/336/CEE et 73/23/CEE modifiées par la directive 93/68/CEE.

Dit apparaat voldoet aan de eisen van de richtlijnen 89/336/EEG en 73/23/EEG, gewijzigd door 93/68/EEG.

Dette udstyr overholder kravene i direktiv nr. 89/336/EEC og 73/23/EEC med tillæg nr. 93/68/EEC.

Quest' apparecchio è conforme ai requisiti delle direttive 89/336/EEC e 73/23/EEC, come emendata dalla direttiva 93/68/EEC.

Η εγκατάσταση αυτή ανταποκρίνεται στις απαιτήσεις των οδηγιών της Ευρωπαϊκής Ένωσης 89/336/EOK και 73/23/EOK, όπως οι κανονισμοί αυτοί συμπληρώθηκαν από την οδηγία 93/68/EOK.

Este equipamento obedece às exigências das directivas 89/336/CEE e 73/23/CEE, na sua versão corrigida pela directiva 93/68/CEE.

Este aparato satisface las exigencias de las Directivas 89/336/CEE y 73/23/CEE, modificadas por medio de la 93/68/CEE.

Denna utrustning uppfyller kraven enligt riktlinjerna 89/336/EEC och 73/23/EEC så som kompletteras av 93/68/EEC.

Dette produktet oppfyller betingelsene i direktivene 89/336/EEC og 73/23/EEC i endringen 93/68/EEC.

Tämä laite täyttää direktiivien 89/336/EEC ja 73/23/EEC vaatimukset, joita on muutettu direktiivillä 93/68/EEC.

The CE mark logo label is affixed on an equipment in case that the directives described in the above sentence are applicable to the product. (This sentence is not applicable in any country where the above directives are not required.)

AR-155/AR-155N

SHARP[®]

SHARP CORPORATION

PRINTED IN CHINA
2000C KS[®]
TINSE0369QSZZ